

GATE 1153

BRONZE

200 lb. SWP-400 lb. WOG† • Industrial Service
 Solid Wedge Disc • Rising Stem
 Union Bonnet • Gland Packed • Threaded Ends

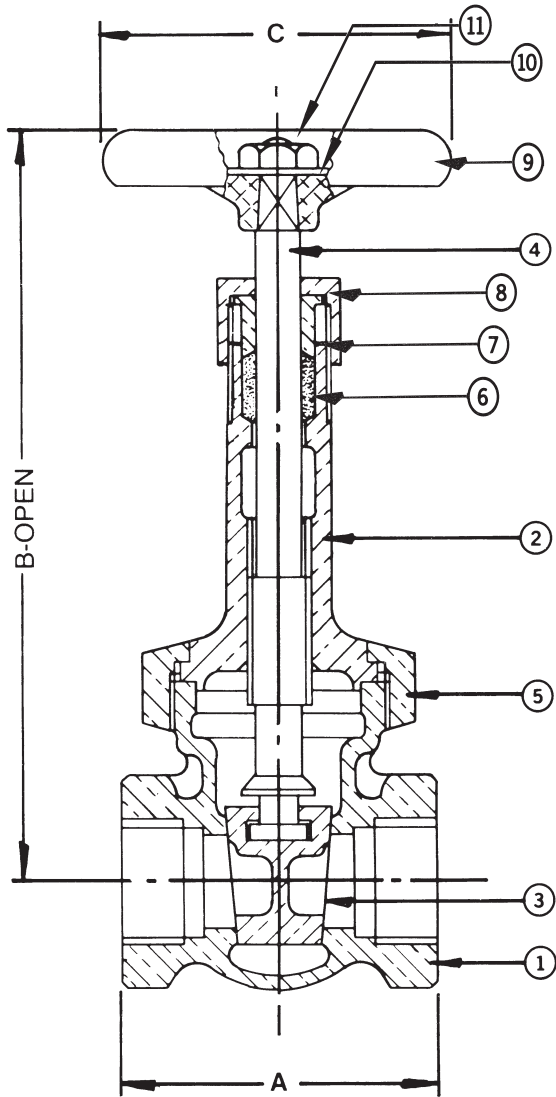

SPECIFICATIONS

1153	Conforms to: MSS SP-80, Type 2, Class 200, Threaded Ends.
------	---

MATERIAL LIST

NO.	PART	MATERIAL	SPECIFICATION
1	Body	Bronze	ASTM B 61
2	Bonnet	Bronze	ASTM B 61
3	Wedge Disc	Bronze	ASTM B 61
4	Stem	Bronze	ASTM B 61
5	Union Bonnet Nut	Bronze	ASTM B 61
6	Packing	Graphite	Commercial
7	Gland	Brass	ASTM B124 C37700
8	Packing Nut	Brass	ASTM B283 C37700
9	Handwheel	Mall. Iron	Commercial
10	Identification Plate	Aluminum	Commercial
11	Handwheel Nut	Brass	Commercial

DIMENSIONS - INCHES / MILLIMETERS

Units	Size	A	B	C	C _v
Inches	1/4	1.75	5.13	2.25	5.6
mm	6.4	44.5	130.2	57.2	5.6
Inches	3/8	1.88	5.13	2.25	10.7
mm	9.5	47.6	130.2	57.2	10.7
Inches	1/2	2.25	5.50	2.50	17.6
mm	12.7	57.2	139.7	63.5	17.6
Inches	3/4	2.50	6.25	2.75	32.0
mm	19.1	63.5	158.8	69.9	32.0
Inches	1	2.88	7.19	2.75	54.0
mm	25.4	73.0	182.6	69.9	54.0
Inches	1 1/4	3.25	8.56	3.25	97.0
mm	31.8	82.6	217.5	82.6	97.0
Inches	1 1/2	3.50	9.56	3.75	135.0
mm	38.1	88.9	242.9	95.3	135.0
Inches	2	3.75	11.75	4.25	230.0
mm	50.8	95.3	298.5	108.0	230.0
Inches	2 1/2	4.63	14.50	4.75	337.0
mm	63.5	117.5	368.3	120.7	337.0
Inches	3	5.00	16.75	5.50	536.0
mm	76.2	127.0	425.5	139.7	536.0

† Non-Shock

Rev. 5

INNOVATION IN EVERY VALVE



MILWAUKEE VALVE

The information presented on this sheet is correct at the time of publication. Milwaukee Valve reserves the right to change design, and/or material specifications without notice. For the Installation, Operation and Maintenance Manual (IOM) see the engineering section on our website. For the most current information access www.milwaukeevalve.com

www.milwaukeevalve.com